

Integrated stepper motor

Model Designation:

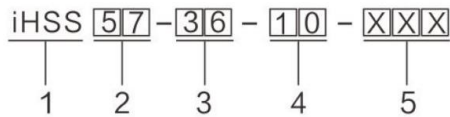

- 1.Integrated Closed Loop Stepper Motor
- 2.Frame size 57mm, Nema 23
- 3.Power supply 36VDC
- 4.Holding Torque:10 is 1N.M. 20 is 2N.M
- 5.Input Control Mode: Blank is Pulse and Signal
R is RS485, RC is RS485 + CAN, EC is EtherCAT



System port:

Communication port:

Model	Pulse mode	RS-485	CANopen
iHSS42	+5V TX	T+ T-	GANH+ GANL-
iHSS57	GND RX	R+ R-	GANH+ GANL-
iHSS60	GND	GND	GND

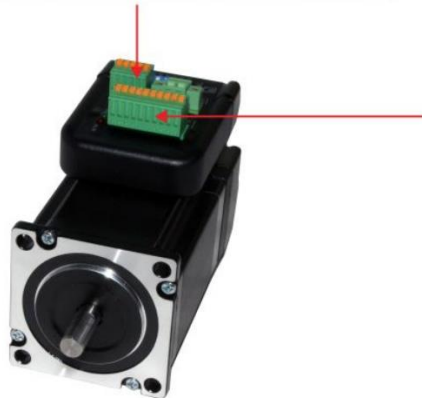

Input/output port:

Model	Pulse mode	RS-485/ CANopen	
iHSS42	PUL+	IN1	
	PUL-	IN2	
	DIR+	IN3	
	DIR-	IN4	
	ENA+	OUT1	
	ENA-	OUT2	
	PEND+	VIN+	
	PEND-	VIN-	
	ALM+	COM+	
	ALM-	COM-	
	+VDC	+VDC	
	GND	GND	
iHSS57	PUL+	IN1	
	PUL-	IN2	
	DIR+	IN3	
	DIR-	IN4	
	ENA+	OUT1	
	ENA-	OUT2	
iHSS60	PEND+	VIN+	
	PEND-	VIN-	
	ALM+	COM+	
	ALM-	COM-	
		+VDC	+VDC
		GND	GND

Switch settings:

iHSS series is steps & direction control, by 6-digit toggle switch to set microsteps, Positive /negative direction, and effective signal, detailed information as following:

Pluse/rev	SW1	SW2	SW3	SW4	Pluse/rev	SW1	SW2	SW3	SW4
Default	On	On	On	On	1000	On	On	On	Off
800	Off	On	On	On	2000	Off	On	On	Off
1600	On	Off	On	On	4000	On	Off	On	Off
3200	Off	Off	On	On	5000	Off	Off	On	Off
6400	On	On	Off	On	8000	On	On	Off	Off
12800	Off	On	Off	On	10000	Off	On	Off	Off
25600	On	Off	Off	On	20000	On	Off	Off	Off
51200	Off	Off	Off	On	40000	Off	Off	Off	Off

Sw5 set motor run direction, when show OFF, the motor is counterclockwise rotation (CCW.) When show on, The motor is clockwise rotation (CW) SW6 setting effective pulse.

Encoder: incremental encoder, 1000 lines (ppr), resolution 1/4000.

● IHSS42-24-05

Integrated stepper motor (closed-loop)

Base: Nema17

Power Supply: 24V

Holding Torque: 0.48Nm



Specifications:

Number of Phase	2	Rotor Inertia	77g.cm ²
Step Angle	1.8°	Dielectric Strength	500VDC
Step Angle Accuracy	±0.09°	Insulation Resistance	100MOHM (500VDC)
Rated Current/phase	1.2A	Insulation Class (UL)	B
Resistance/phase	3.1Ω±10%	Temperature Rise Max	80C°
Inductance/phase	7.9MH±20%	Radial Play	Max 0.025mm (load 450g)
Holding Torque	0.48Nm	Axial Play	Max 0.075mm (load 920g)

Torque Curve:

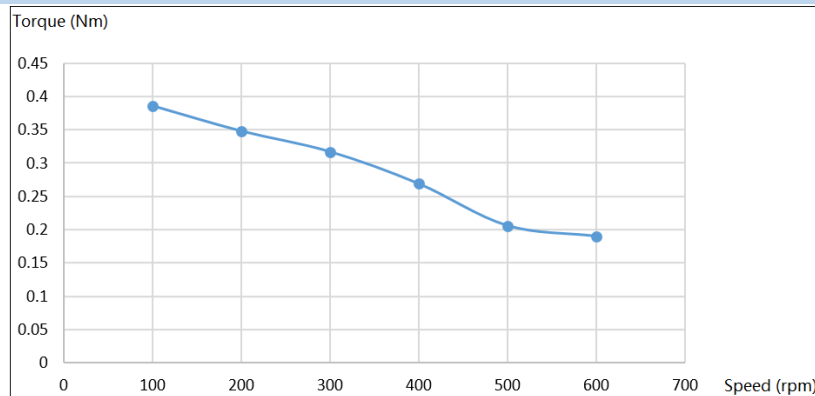

Drawing:

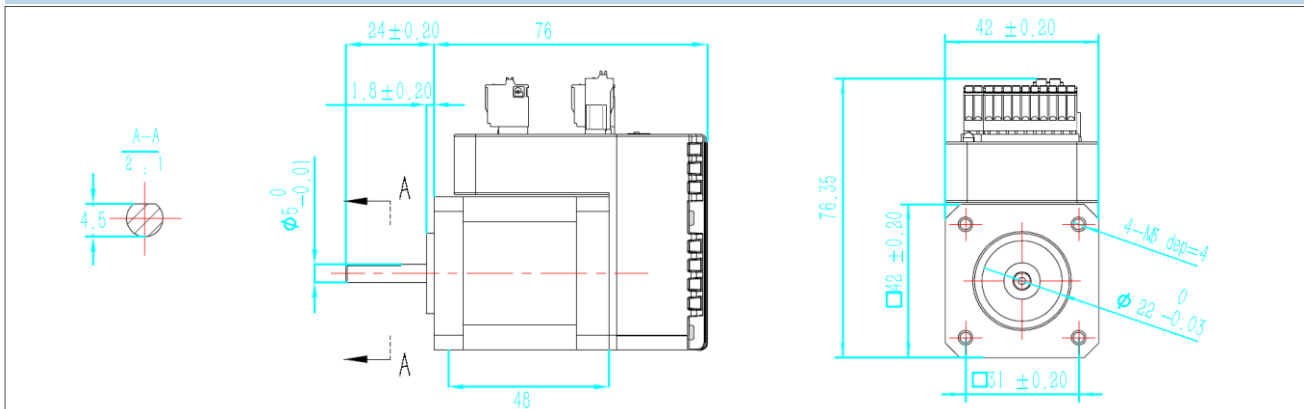

● IHSS57-36-10

Integrated stepper motor (closed-loop)

Base: Nema23

Power Supply: 36V

Holding Torque: 1.2Nm



Specifications:

Number of Phase	2	Rotor Inertia	280g.cm ²
Step Angle	1.8°	Dielectric Strength	500VDC
Step Angle Accuracy	±0.09°	Insulation Resistance	100MOHM (500VDC)
Rated Current/phase	4A	Insulation Class (UL)	B
Resistance/phase	0.44Ω±10%	Temperature Rise Max	80K
Inductance/phase	1.4MH±20%	Radial Play	Max 0.025mm (load 450g)
Holding Torque	1.2Nm	Axial Play	Max 0.075mm (load 920g)

Torque Curve:

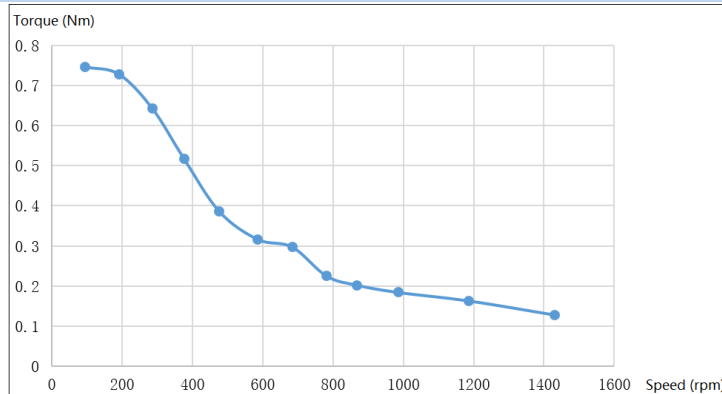

Drawing:

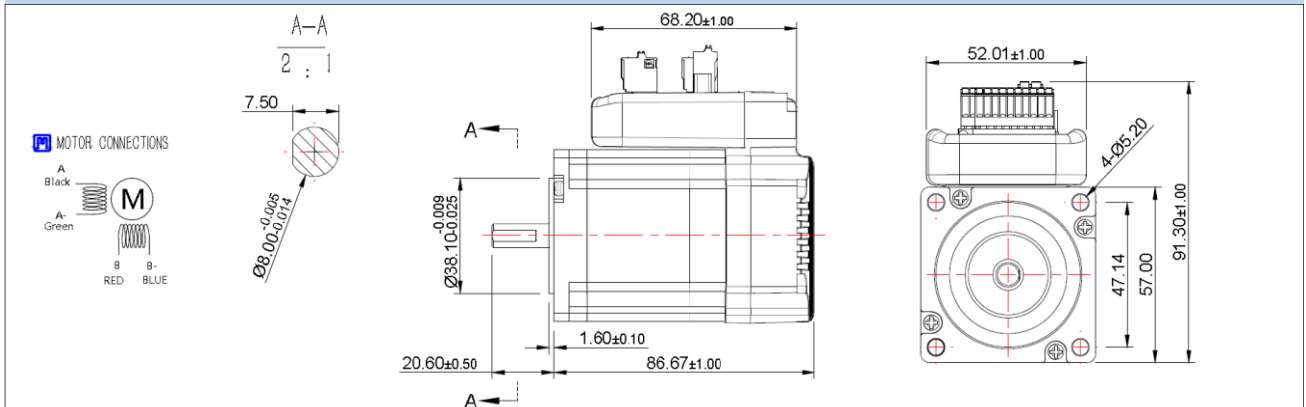

● IHSS57-36-20

Integrated stepper motor (closed-loop)

Base: Nema23

Power Supply: 36V

Holding Torque: 2Nm



Specifications:

Number of Phase	2	Rotor Inertia	480g.cm ²
Step Angle	1.8°	Dielectric Strength	500VDC
Step Angle Accuracy	±0.09°	Insulation Resistance	100MOHM (500VDC)
Rated Current/phase	5A	Insulation Class (UL)	B
Resistance/phase	0.37Ω±10%	Temperature Rise Max	80K
Inductance/phase	1.7MH±20%	Radial Play	Max 0.025mm (load 450g)
Holding Torque	2Nm	Axial Play	Max 0.075mm (load 920g)

Torque Curve:

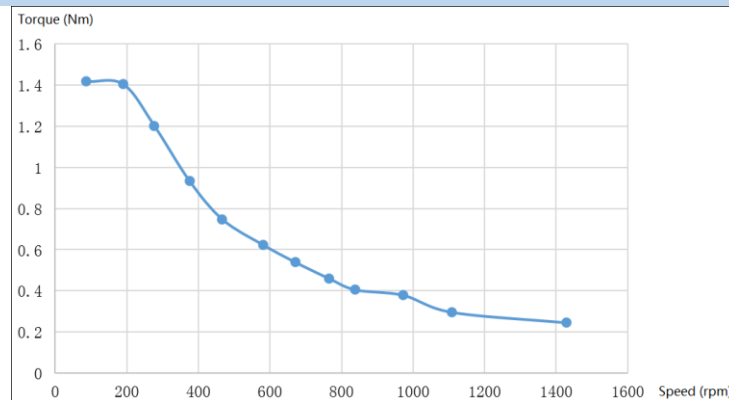

Drawing:

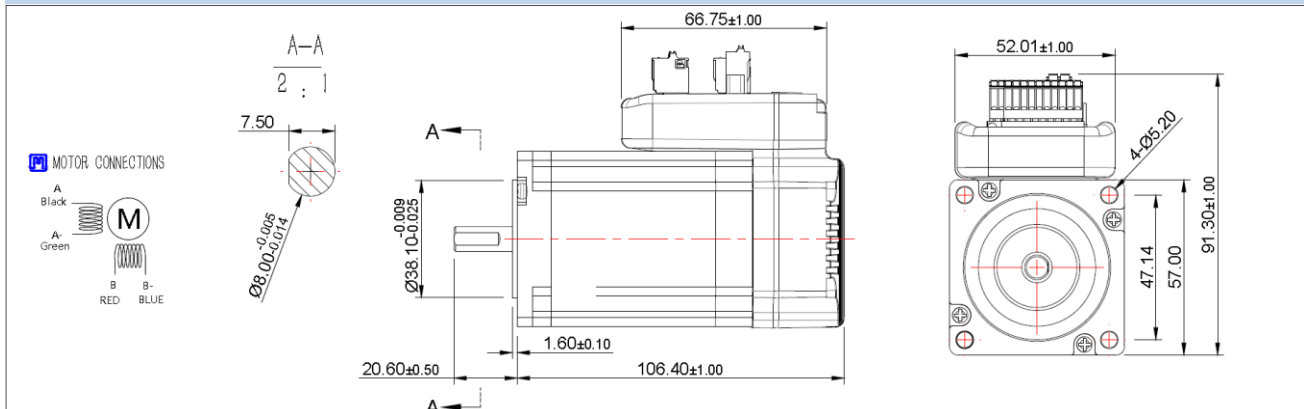

● IHSS60-36-30

Integrated stepper motor (closed-loop)

Base: Nema24

Power Supply: 36V

Holding Torque: 3Nm



Specifications:

Number of Phase	2	Rotor Inertia	690g.cm ²
Step Angle	1.8°	Dielectric Strength	500VDC
Step Angle Accuracy	±0.09°	Insulation Resistance	100MOHM (500VDC)
Rated Current/phase	5A	Insulation Class (UL)	B
Resistance/phase	0.43Ω±10%	Temperature Rise Max	80K
Inductance/phase	2.0MH±20%	Radial Play	Max 0.025mm (load 450g)
Holding Torque	3Nm	Axial Play	Max 0.075mm (load 920g)

Torque Curve:

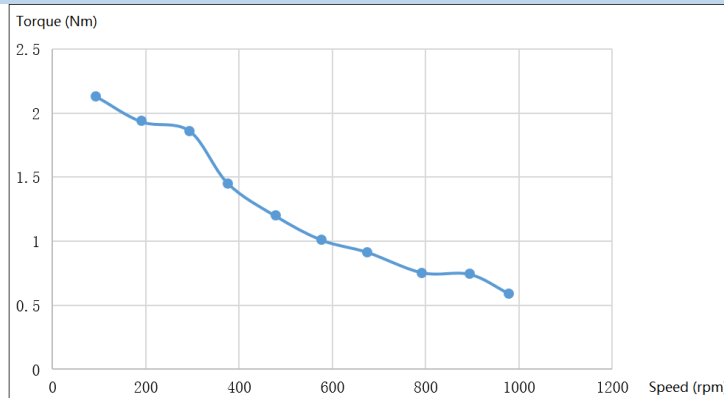

Drawing:

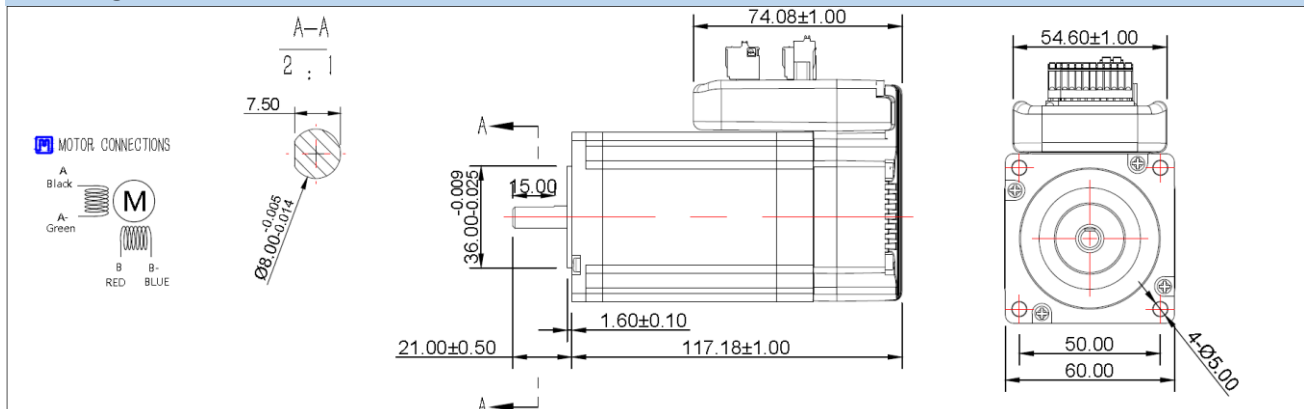

● IHSS86-60-45

Integrated stepper motor (closed-loop)

Base: Nema34

Power Supply: 60V

Holding Torque: 4.5Nm



Specifications:

Number of Phase	2	Rotor Inertia	1800g.cm ²
Step Angle	1.8°	Dielectric Strength	500VDC
Step Angle Accuracy	±0.09°	Insulation Resistance	100MOHM (500VDC)
Rated Current/phase	6A	Insulation Class (UL)	B
Resistance/phase	0.43Ω±10%	Temperature Rise Max	80K
Inductance/phase	2.7MH±20%	Radial Play	Max 0.025mm (load 450g)
Holding Torque	4.5Nm	Axial Play	Max 0.075mm (load 920g)

Torque Curve:

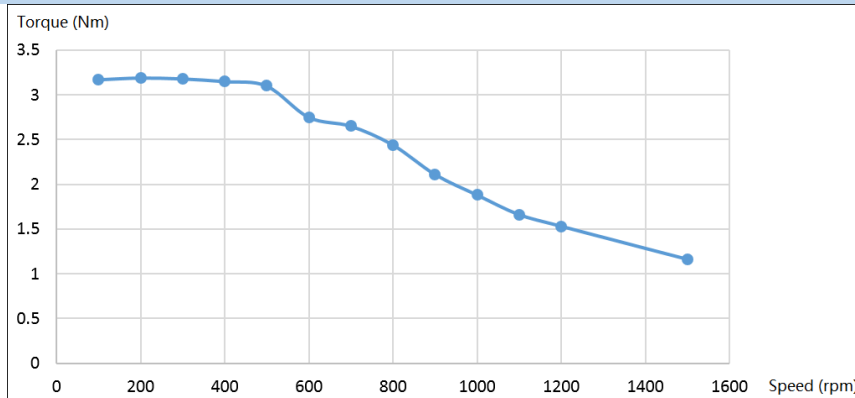

Drawing:

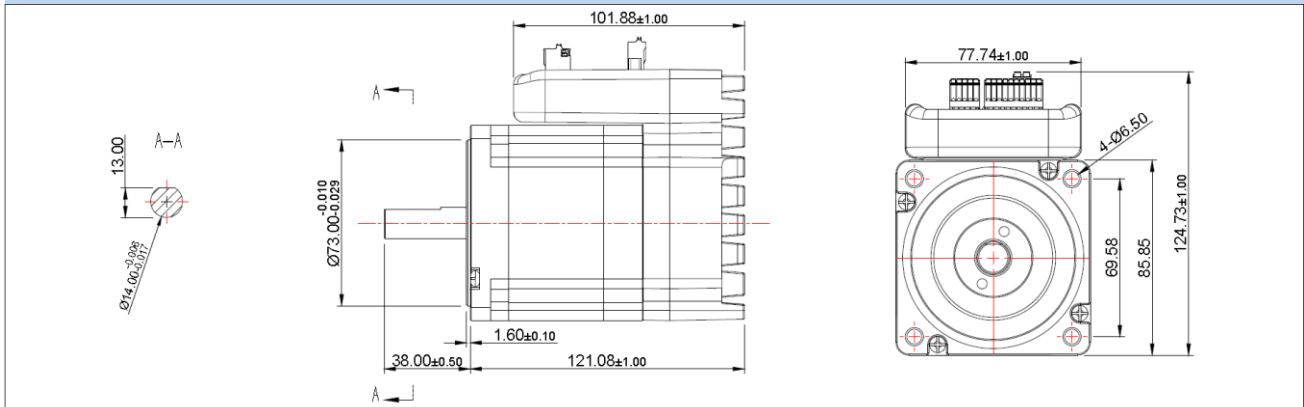

● IHSS86-80-100

Integrated stepper motor (closed-loop)

Base: Nema34

Power Supply: 80V

Holding Torque: 9.8Nm



Specifications:

Number of Phase	2	Rotor Inertia	3100g.cm ²
Step Angle	1.8°	Dielectric Strength	500VDC
Step Angle Accuracy	±0.09°	Insulation Resistance	100MOHM (500VDC)
Rated Current/phase	6A	Insulation Class (UL)	B
Resistance/phase	0.57Ω±10%	Temperature Rise Max	80K
Inductance/phase	3.7MH±20%	Radial Play	Max 0.025mm (load 450g)
Holding Torque	9.8Nm	Axial Play	Max 0.075mm (load 920g)

Torque Curve:

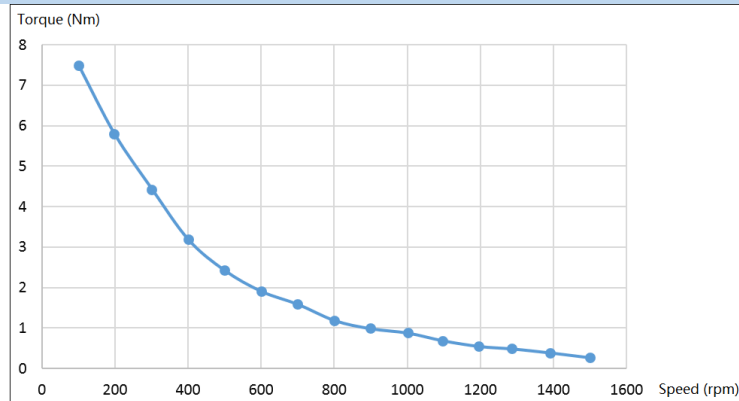

Drawing:

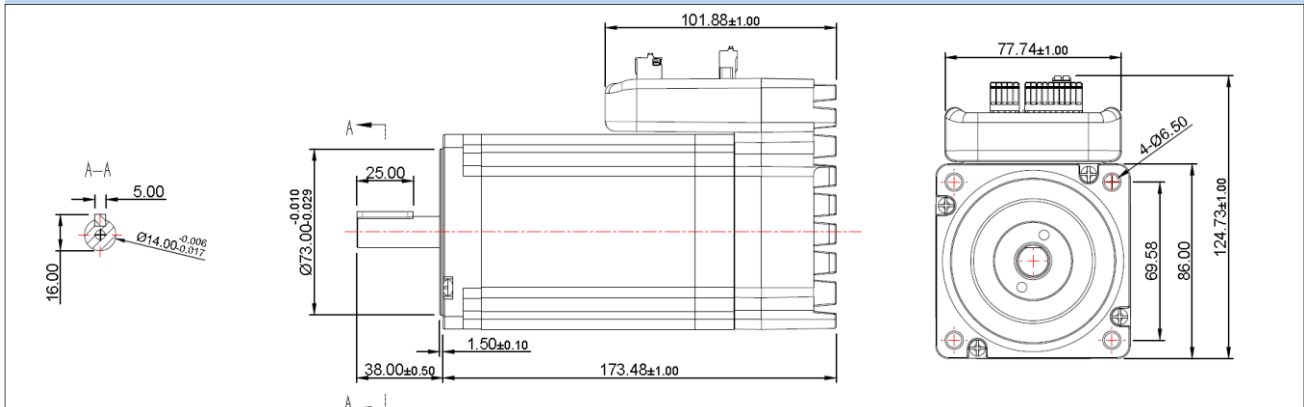

Integrated servo motor

Model Designation:

iHSV 57 - 30 - 10 - 24 - XXX

1 2 3 4 5 6

1. Integrated Servo Motor
2. Frame size 57mm/60mm, Nema 23/24
3. Motor Speed(unit:x100RPM)
10 is 1000RPM, 20 is 2000RPM, 30 is 3000RPM
4. Output Wattage(unit:x10W)
10 is 100W, 20 is 200W
5. Rated DC Working Voltage(unit:V)
24 is 24VDC, 36V is 36VDC.
6. Input Control Mode
Blank is Pulse+Signal; R is RS485, RC is RS485 + CAN, EC is EtherCAT

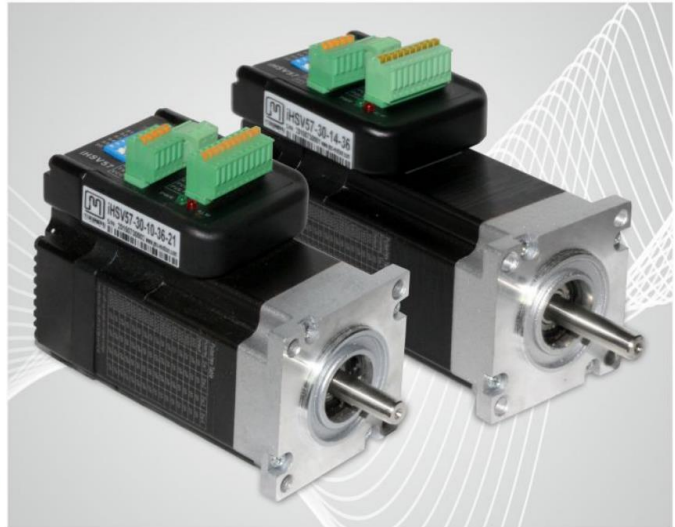

Main Features:

- High positioning accuracy
- High speed
- High torque
- Smooth and low noise
- Multi-model control
- High Response
- Cost-effective
- Compact size

IHSV series of servo motors perfectly integrated into servo control products to create a revolutionary movement with a new and high performance integrated control terminal.

Switch settings:

IHSV series is step & direction control, by 6-digit toggle switch to set microsteps, Positive / negative direction, and effective signal. Detailed information as following:

Pluse/rev	SW1	SW2	SW3	SW4	Pluse/rev	SW1	SW2	SW3	SW4
Default	On	On	On	On	1000	On	On	On	Off
800	Off	On	On	On	2000	Off	On	On	Off
1600	On	Off	On	On	4000	On	Off	On	Off
3200	Off	Off	On	On	5000	Off	Off	On	Off
6400	On	On	Off	On	8000	On	On	Off	Off
12800	Off	On	Off	On	10000	Off	On	Off	Off
25600	On	Off	Off	On	20000	On	Off	Off	Off
51200	Off	Off	Off	On	40000	Off	Off	Off	Off

Sw5 set motor run direction, when show OFF, the motor is counterclockwise rotation (CCW.) When show on, the motor is clockwise rotation (CW) SW6 setting effective pulse.

- **Encoder:** incremental encoder, 1000 lines (ppr), resolution 1/4000.

● IHSV42-40-05-24

Integrated servo motor

Rated Voltage: 24V

Rated Power: 52W

Rated Torque: 0.125Nm



Specifications:

Number of Phase	3	Line-line Resistance: $\Omega \pm 10\%$	
Rated Voltage: V	24	Line-line Inductance: $\text{mH} \pm 20\%$	
Rated Power: W	52	Rated Torque: Nm	0.125
Rated Speed: $\text{rpm} \pm 7\%$	3000	Torque Coefficient: Nm/A	0.044
No-load Speed: $\text{rpm} \pm 7\%$	5200	Back EMF constant: V/krpm	3.26
Rated Current: $\text{A} \pm 20\%$	3.4	Rotor Inertia: $\text{kg} \cdot \text{mm}^2$	9.5
No-load Current: A	0.45	Insulation Class (UL)	B

Torque characteristics:

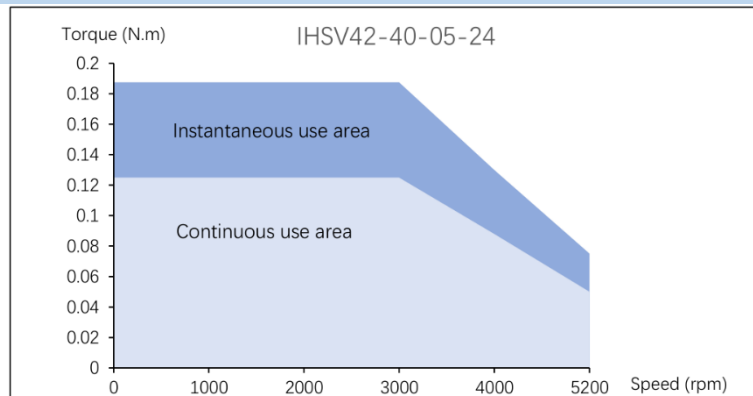

Drawing:

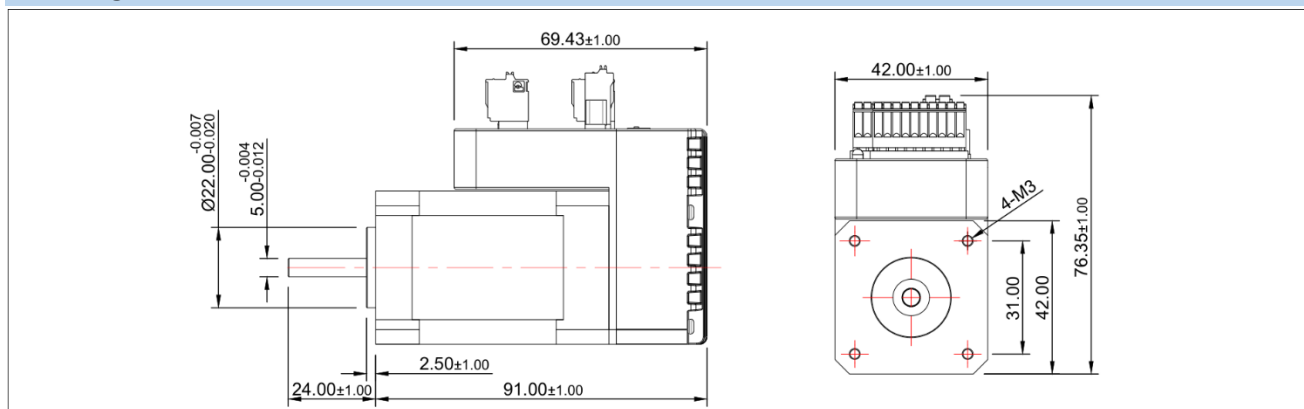

● IHSV42-40-07-24

Integrated servo motor

Rated Voltage: 24V

Rated Power: 78W

Rated Torque: 0.185Nm



Specifications:

Number of Phase	3	Line-line Resistance: $\Omega \pm 10\%$	
Rated Voltage: V	24	Line-line Inductance: $MH \pm 20\%$	
Rated Power: W	78	Rated Torque: Nm	0.185
Rated Speed: $rpm \pm 7\%$	3000	Torque Coefficient: Nm/A	0.044
No-load Speed: $rpm \pm 7\%$	5200	Back EMF constant: V/krpm	3.26
Rated Current: $A \pm 20\%$	5.1	Rotor Inertia: $kg \cdot mm^2$	14.7
No-load Current: A	0.6	Insulation Class (UL)	B

Torque characteristics:

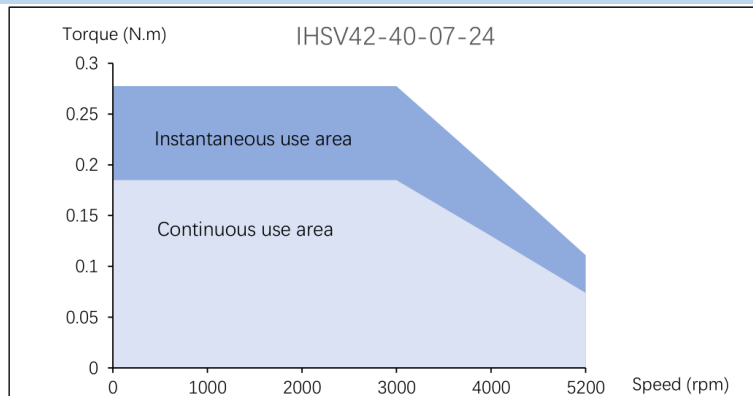

Drawing:

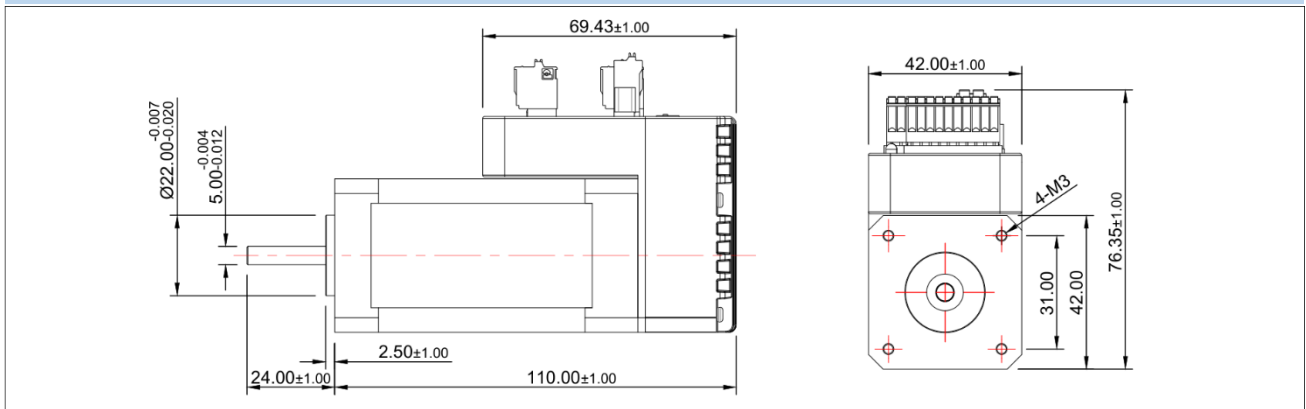

● IHSV57-30-10-36

Integrated servo motor

Rated Voltage: 36V

Rated Power: 100W

Rated Torque: 0.29Nm



Specifications:

Number of Phase	3	Line-line Resistance: $\Omega \pm 10\%$	1.19
Rated Voltage: V	36	Line-line Inductance: $\text{MH} \pm 20\%$	1.2
Rated Power: W	100	Rated Torque: Nm	0.29
Rated Speed: $\text{rpm} \pm 7\%$	3000	Torque Coefficient: Nm/A	
No-load Speed: $\text{rpm} \pm 7\%$	4200	Back EMF constant: V/krpm	
Rated Current: $\text{A} \pm 20\%$	3.5	Rotor Inertia: $\text{kg} \cdot \text{mm}^2$	
No-load Current: A		Insulation Class (UL)	B

Torque characteristics:

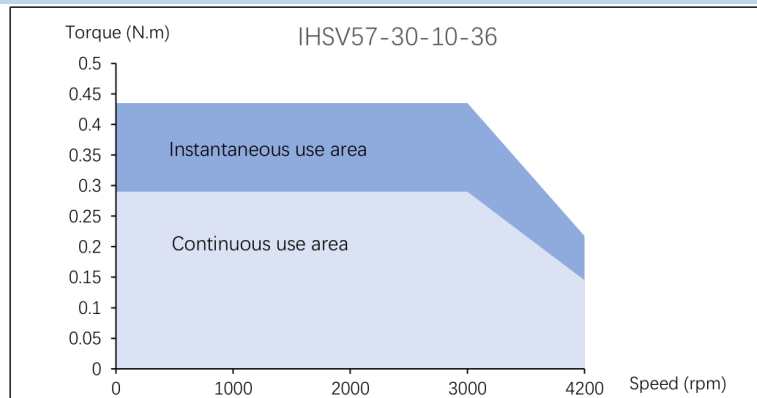

Drawing:

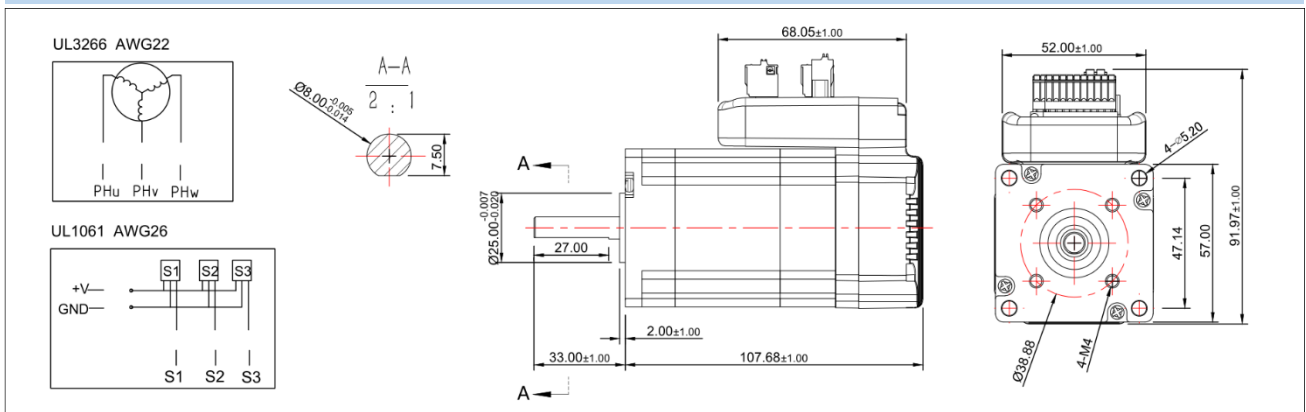

● IHSV57-30-14-36

Integrated servo motor

Rated Voltage: 36V

Rated Power: 140W

Rated Torque: 0.45Nm



Specifications:

Number of Phase	3	Line-line Resistance: $\Omega \pm 10\%$	0.78
Rated Voltage: V	36	Line-line Inductance: $MH \pm 20\%$	0.84
Rated Power: W	140	Rated Torque: Nm	0.45
Rated Speed: $rpm \pm 7\%$	3000	Torque Coefficient: Nm/A	0.08
No-load Speed: $rpm \pm 7\%$	4200	Back EMF constant: V/krpm	
Rated Current: $A \pm 20\%$	5.4	Rotor Inertia: $kg \cdot mm^2$	
No-load Current: A	0.55	Insulation Class (UL)	B

Torque characteristics:

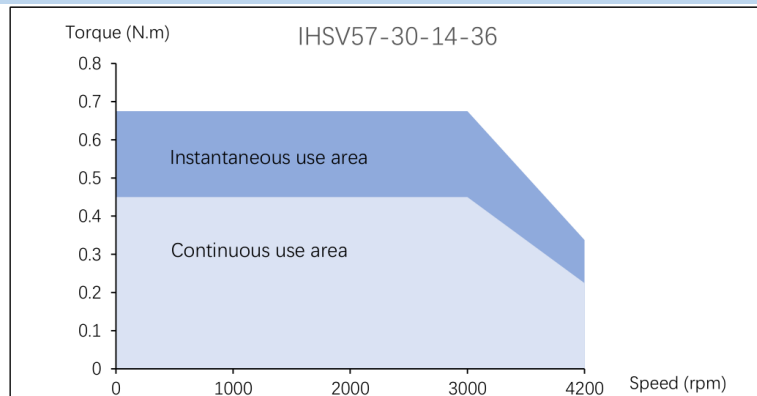

Drawing:

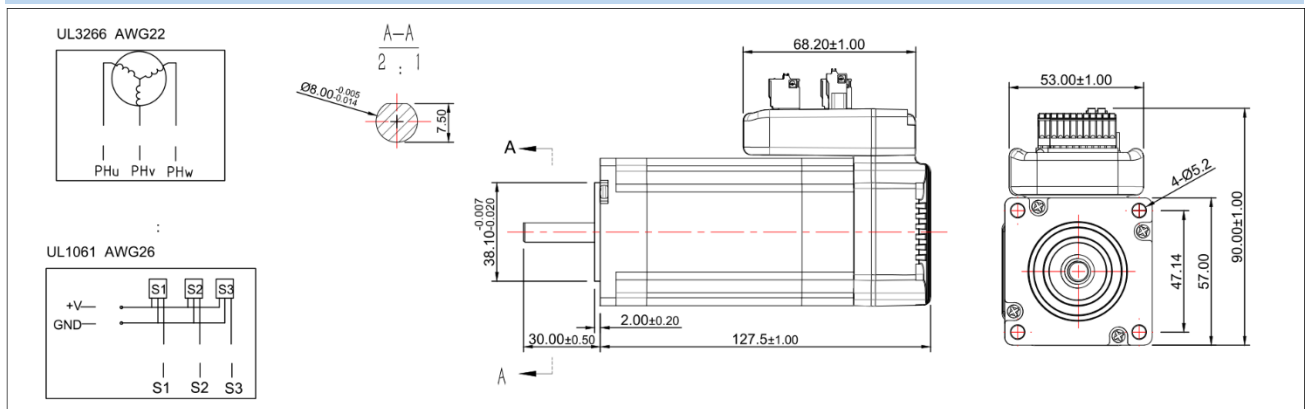

● IHSV57-30-18-36

Integrated servo motor

Rated Voltage: 36V

Rated Power: 180W

Rated Torque: 0.6Nm



Specifications:

Number of Phase	3	Line-line Resistance: $\Omega \pm 10\%$	0.53
Rated Voltage: V	36	Line-line Inductance: $MH \pm 20\%$	0.58
Rated Power: W	180	Rated Torque: Nm	0.6
Rated Speed: $rpm \pm 7\%$	3000	Torque Coefficient: Nm/A	0.082
No-load Speed: $rpm \pm 7\%$	4200	Back EMF constant: V/krpm	
Rated Current: $A \pm 20\%$	7.5	Rotor Inertia: $kg \cdot mm^2$	
No-load Current: A	0.65	Insulation Class (UL)	B

Torque characteristics:

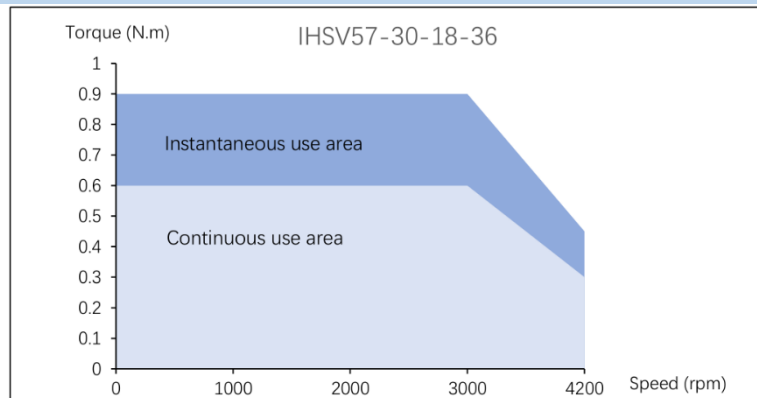

Drawing:

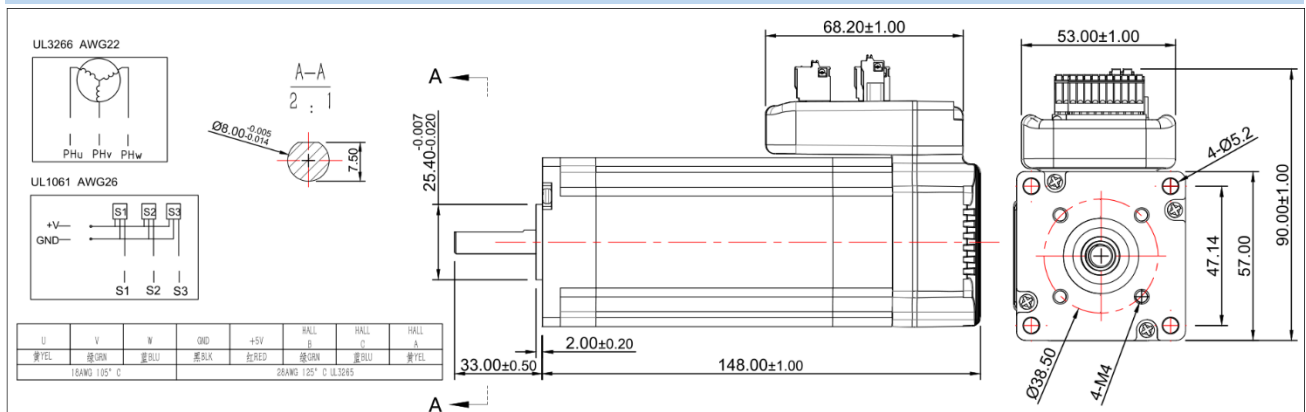

● IHSV60-30-20-36

Integrated servo motor

Rated Voltage: 36V

Rated Power: 200W

Rated Torque: 0.65Nm



Specifications:

Number of Phase	3	Line-line Resistance: $\Omega \pm 10\%$	0.6
Rated Voltage: V	36	Line-line Inductance: $MH \pm 20\%$	
Rated Power: W	200	Rated Torque: Nm	0.65
Rated Speed: $rpm \pm 7\%$	3000	Torque Coefficient: Nm/A	0.082
No-load Speed: $rpm \pm 7\%$	4200	Back EMF constant: V/krpm	
Rated Current: $A \pm 20\%$	8.5	Rotor Inertia: $kg \cdot mm^2$	32.5
No-load Current: A	0.8	Insulation Class (UL)	B

Torque characteristics:

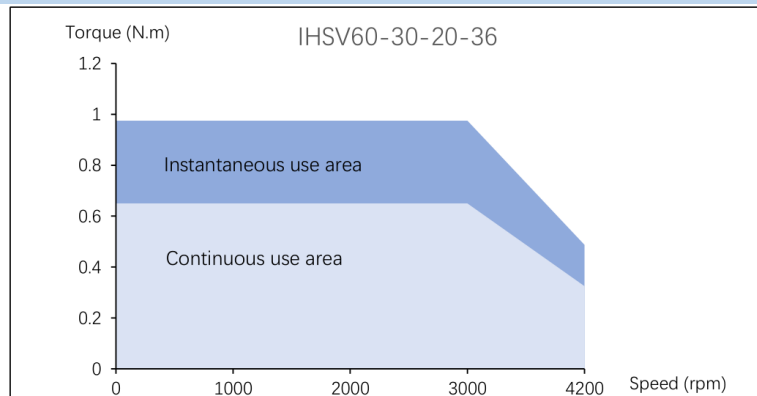

Drawing:

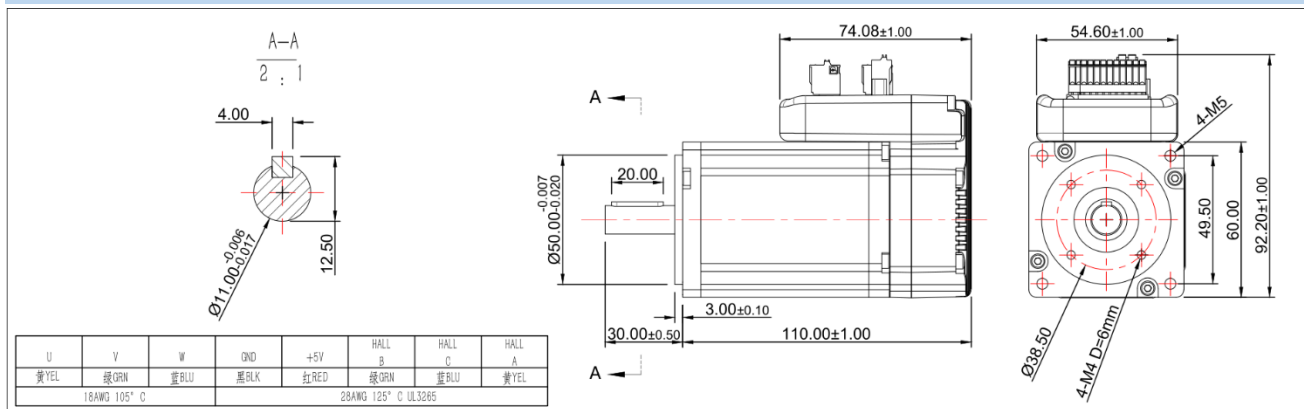

● IHSV60-30-40-48

Integrated servo motor

Rated Voltage: 48V

Rated Power: 400W

Rated Torque: 1.27Nm



Specifications:

Number of Phase	3	Line-line Resistance: $\Omega \pm 10\%$	0.6
Rated Voltage: V	48	Line-line Inductance: $\text{MH} \pm 20\%$	
Rated Power: W	400	Rated Torque: Nm	1.27
Rated Speed: $\text{rpm} \pm 7\%$	3000	Torque Coefficient: Nm/A	0.082
No-load Speed: $\text{rpm} \pm 7\%$	4200	Back EMF constant: V/krpm	
Rated Current: $\text{A} \pm 20\%$	11.2	Rotor Inertia: $\text{kg} \cdot \text{mm}^2$	68
No-load Current: A	1.2	Insulation Class (UL)	B

Torque characteristics:

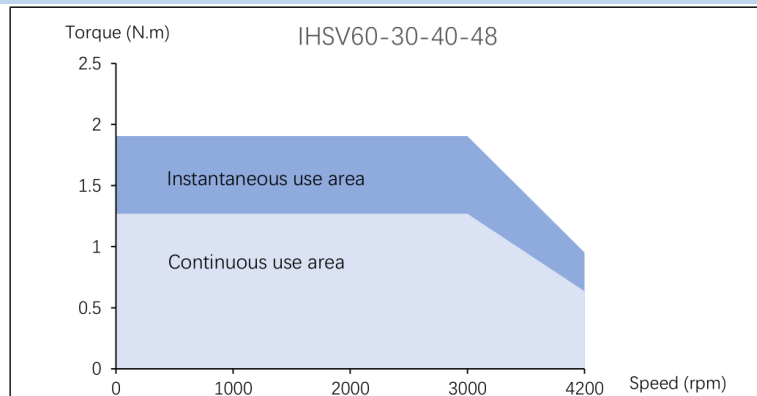

Drawing:

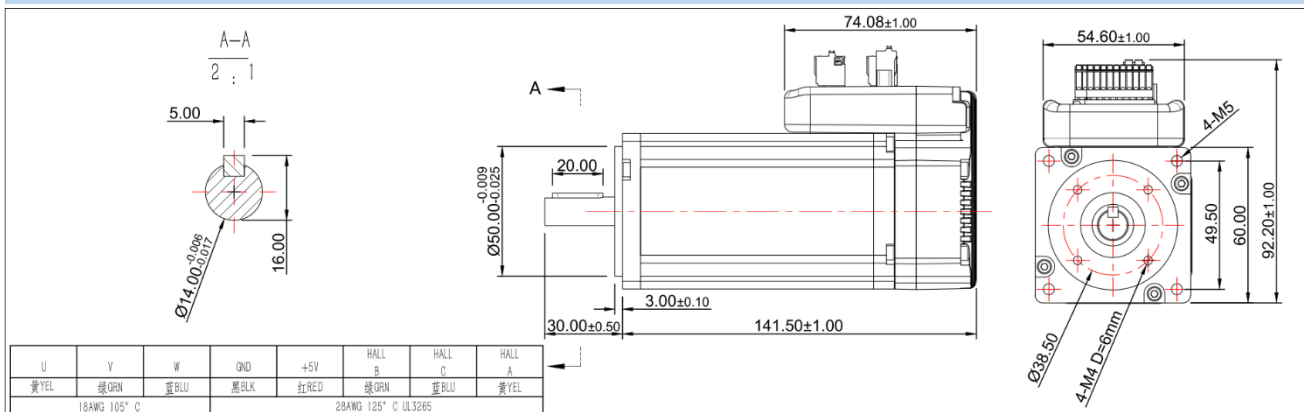

● IHSV86-30-44-48

Integrated servo motor

Rated Voltage: 48V

Rated Power: 440W

Rated Torque: 1.4Nm

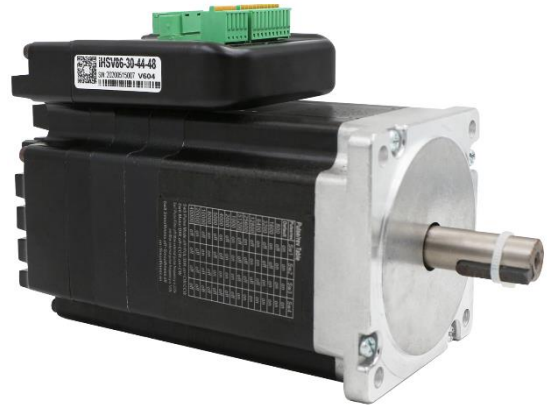

Specifications:

Number of Phase	3	Line-line Resistance: $\Omega \pm 10\%$	
Rated Voltage: V	48	Line-line Inductance: $\text{mH} \pm 20\%$	
Rated Power: W	440	Rated Torque: Nm	1.4
Rated Speed: $\text{rpm} \pm 7\%$	3000	Torque Coefficient: Nm/A	
No-load Speed: $\text{rpm} \pm 7\%$	4200	Back EMF constant: V/krpm	
Rated Current: $\text{A} \pm 20\%$	13.1	Rotor Inertia: $\text{kg} \cdot \text{mm}^2$	32.5
No-load Current: A		Insulation Class (UL)	B

Torque characteristics:

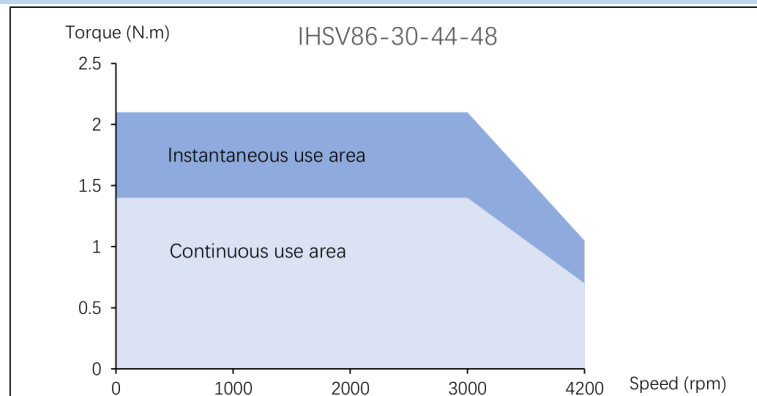

Drawing:

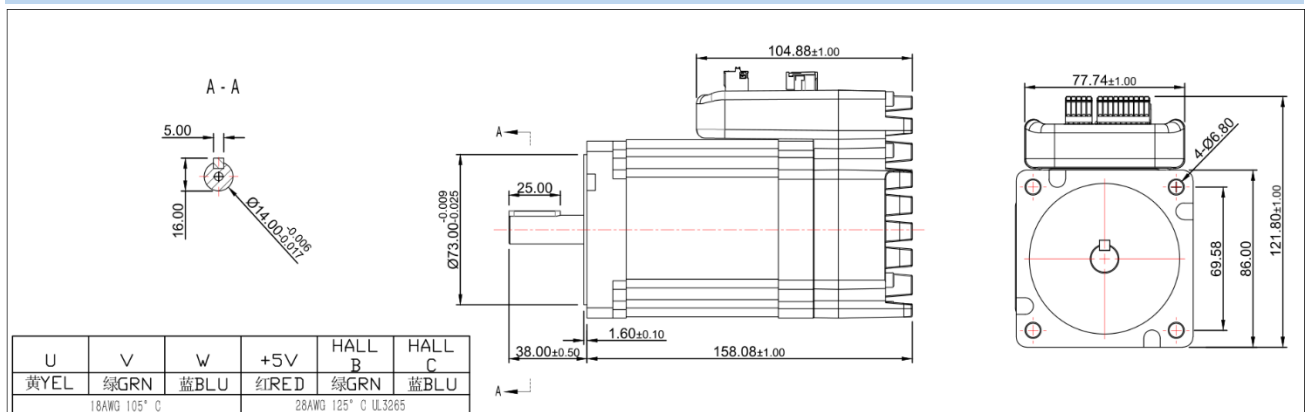

● IHSV86-30-66-72

Integrated servo motor

Rated Voltage: 72V

Rated Power: 660W

Rated Torque: 2.03Nm

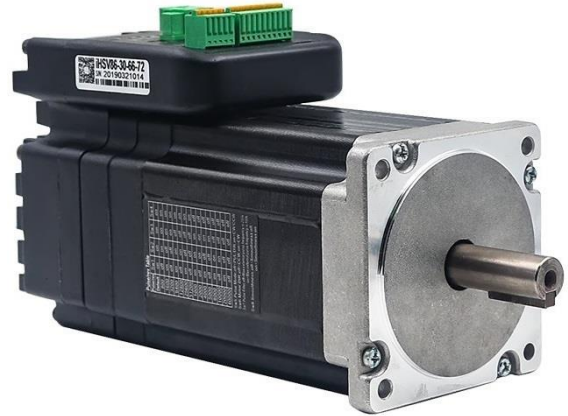

Specifications:

Number of Phase	3	Line-line Resistance: $\Omega \pm 10\%$	
Rated Voltage: V	72	Line-line Inductance: $\text{MH} \pm 20\%$	
Rated Power: W	660	Rated Torque: Nm	2.03
Rated Speed: $\text{rpm} \pm 7\%$	3000	Torque Coefficient: Nm/A	
No-load Speed: $\text{rpm} \pm 7\%$	4200	Back EMF constant: V/krpm	
Rated Current: $\text{A} \pm 20\%$	13.1	Rotor Inertia: $\text{kg} \cdot \text{mm}^2$	
No-load Current: A		Insulation Class (UL)	B

Torque characteristics:

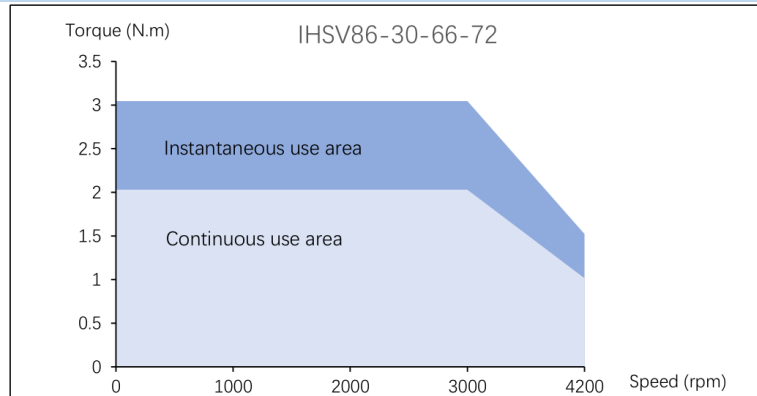

Drawing:

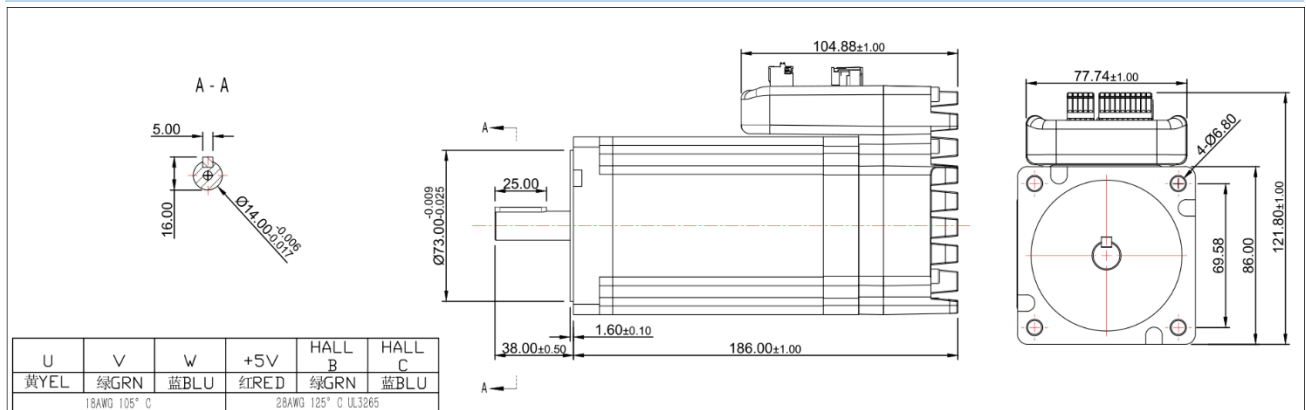

Fieldbus integrated motor

● Fieldbus integrated stepper motor

Brief Introduction:

IHSS-R/RC/EC Fieldbus integrated hybrid step-servo motors are RS485/CAN/EtherCAT Fieldbus integrated hybrid step-servo motors. It supports standard Modbus-RTU, CANopen and EtherCAT (COE) protocol, and built-in Cyclic synchronous position mode (CSP), Cyclic synchronous velocity mode (CSV), Profile position mode (PP), Profile velocity mode (PV), Homing mode (HM) of CIA402 motion control protocol. The most advanced 32bit DSP processor and motor algorithm, can makes the motor runs smoothly in low speed, and output higher torque in medium and higher running speed. It can replace the servo system in some applications; with physic rotary code, you can set slave ID, baud rate, integrated 5 digital signal input used for HM refer, CW, CCW limit, and probe function (only for EC series). It integrates 2 digital signal output used for the brake control signal, alarm and arrival signal. It has the function for the brake control circuit, and over current, over voltage, short voltage, position error protection. The RJ45 network communication interface, highly integrated design, combines the control drive system with hybrid step servo motor into an integrated version, no need for encoder cable, motor cable and signal cable. This makes convenient connecting and less complicated system. It is a high cost-performance industrial Fieldbus motion control product.

Selection Table:

RS485	RS485 + CAN	EtherCAT	Holding Torque	Power Supply	Digital Signal
IHSS57-36-20-R	IHSS57-36-20-RC	IHSS57-36-20-EC	2N.m	36VDC	Digital Input: Current: 6-16mA Voltage: 5-24VDC Digital Output: Current: 0-50mA Voltage: 0-30VDC
IHSS60-36-30-R	IHSS60-36-30-RC	IHSS60-36-30-EC	3N.m		
IHSS86-60-45-R	IHSS86-60-45-RC	IHSS86-60-45-EC	4.5N.m	60VDC	
IHSS86-80-85-R	IHSS86-80-85-RC	IHSS86-80-85-EC	8.5N.m	80VDC	

Note: EC is not for overseas yet. After fully tested, it will be promoted.

Interface Configuration Diagram:



● Fieldbus integrated servo motor

Brief Introduction:

IHSV-R/RC/EC Fieldbus integrated ac servo motors are RS485/CAN/EtherCAT Fieldbus integrated servo motors. It supports standard Modbus-RTU, CANopen and EtherCAT (COE) protocol, and built-in Cyclic synchronous position mode (CSP), Cyclic synchronous velocity mode (CSV), Cyclic synchronous torque mode (CST), Profile position mode (PP), Profile velocity mode (PV), Profile torque mode (PT), Homing mode (HM) of CIA402 motion control protocol. Through an optimized PID control algorithm, it realizes full digital control of position, speed, torque, and has the advantages of high accuracy and fast response. It integrates 3 digital signal inputs used for HM refer, CW, CCW limit, and probe function (only for EC series). It integrates 1 digital signal output used for the alarm and arrival signal. It has the function for brake control circuit, and over current, over-voltage, short-voltage, and position error protection. The RJ45 network communication interface, highly integrated design, no need for encoder cable, motor cable, and signal cable. This makes convenient wiring and less complicated system. It is a high cost-performance industrial Fieldbus motion control product.

Selection Table:

RS485	RS485 + CAN	EtherCAT	Rated Torque	Power Supply	Digital Signal
IHSV57-30-14-36-R	IHSV57-30-14-36-RC	IHSV57-30-14-36-EC	0.45N.m	36VDC	Input: Current: 6-16mA Voltage: 5-24VDC Output: Current: 0-50mA Voltage: 0-30VDC
IHSV57-30-18-36-R	IHSV57-30-18-36-RC	IHSV57-30-18-36-EC	0.6N.m		
IHSV60-30-20-36-R	IHSV60-30-20-36-RC	IHSV60-30-20-36-EC	0.65N.m		
IHSV60-30-40-48-R	IHSV60-30-40-48-RC	IHSV60-30-40-48-EC	1.27N.m	48VDC	
IHSV86-30-44-72-R	IHSV86-30-44-72-RC	IHSV86-30-44-72-EC	1.4N.m	72VDC	
IHSV86-30-66-72-R	IHSV86-30-66-72-RC	IHSV86-30-66-72-EC	2.03N.m		

Note: EC is not for overseas yet. After fully tested, it will be promoted.

Interface Configuration Diagram:

